

Installation and Operating Handbook
ANALOGUE

Autohelm 1000

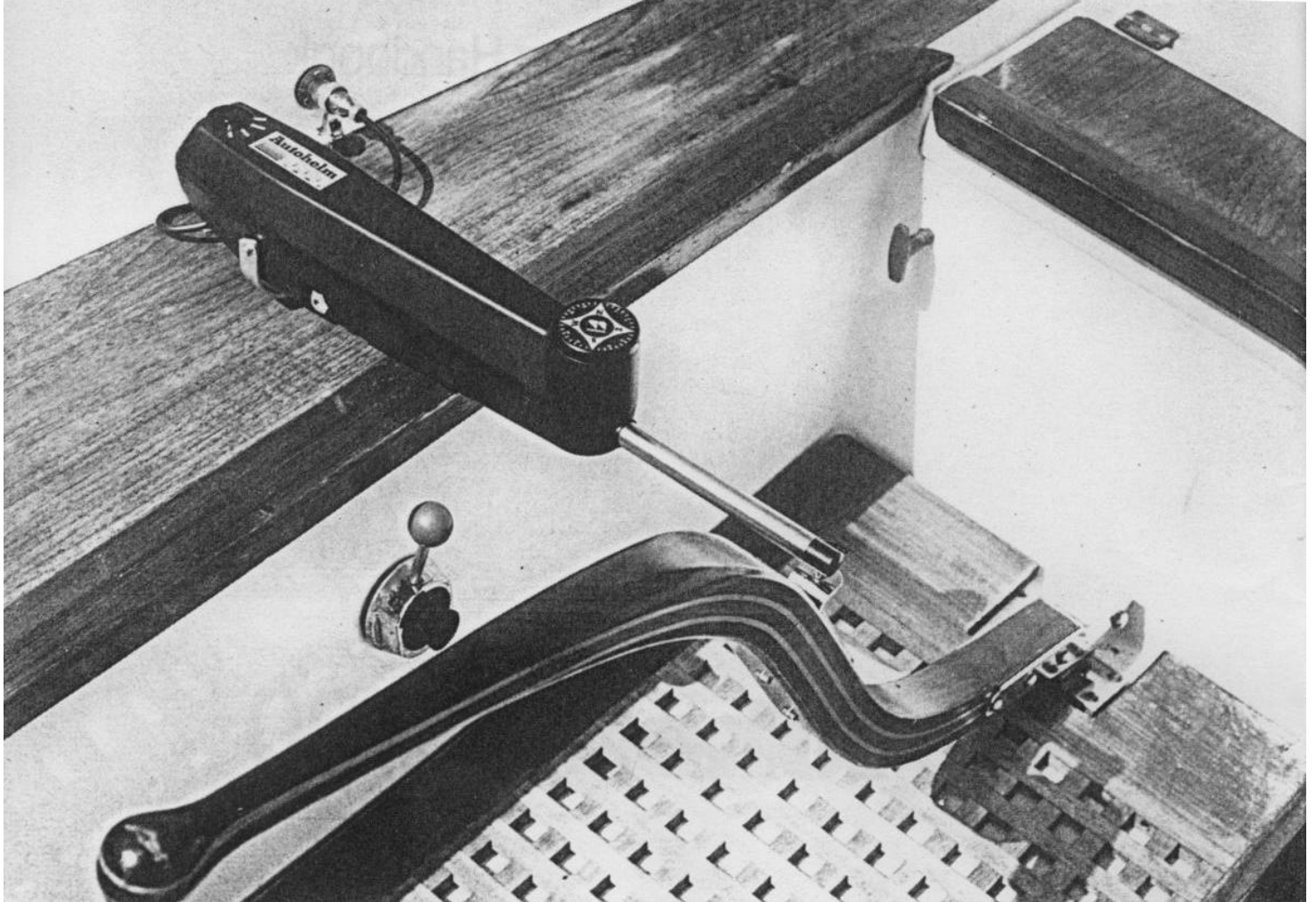

The Autohelm 1000 is a highly developed autopilot built to operate reliably in exposed marine conditions. When correctly installed it will soon become a vital crew-member giving many years of invaluable service.

The system has been designed for owner installation and aided by the following installation guide, fitting should prove to be a straightforward and enjoyable job.

Cockpit and tiller configurations vary widely, and thus in some cases special attachments may be necessary to effect the neatest possible installation. The attachments available and their applications are fully described and are stocked for immediate supply when required.

In cases where special advice is needed you are encouraged to contact our Technical Sales Department who will be pleased to assist.

INSTALLATION

The basic actuator unit is a totally self-contained magnetic sensing automatic pilot. The autopilot is mounted between the tiller and a single attachment point to the yacht's structure. After connection to the yacht's 12 volt electrical system the unit becomes operational.

Since the autopilot incorporates a magnetic sensing device, it is advisable to ensure that the yacht's steering compass is situated at least 2'6" (750mm) away to avoid deviation.

The actuator pushrod attaches to the tiller via a ball-ended pin situated 18" (460mm) radially distant from the rudder stock or rudder pintle centreline.

If the rudder pivot axis is sloping, the position of the ball-ended pin must be positioned at a radius of 18" (460mm) at 90 degrees to the axis of rudder rotation as shown on the accompanying illustration.

The autopilot slots into the bronze mounting socket A provided, which should be permanently fixed in position. The mounting socket should be positioned 19" (480mm) to **starboard** of the cockpit centreline to ensure that port and starboard tiller movements are equalised. It is also important to ensure that the unit is positioned horizontally and as near as possible to 90 degrees to the tiller when the tiller is centralised.

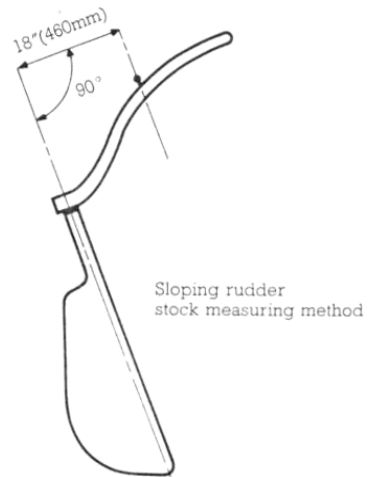
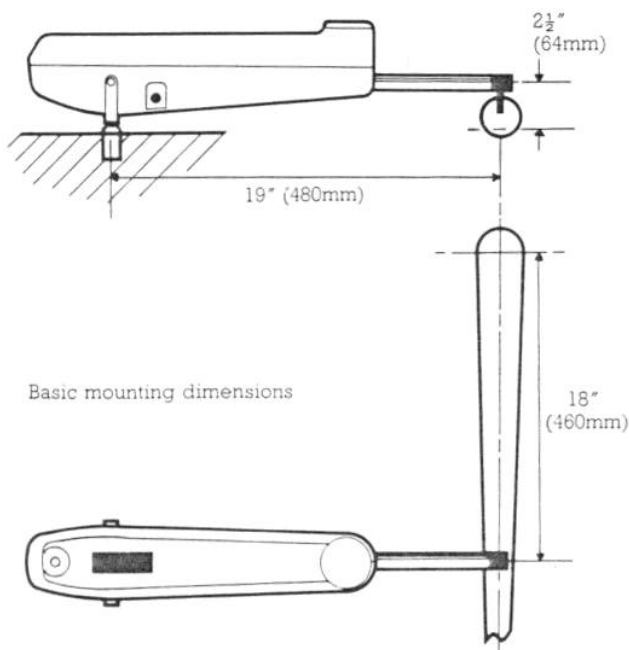

Porthand mounting

In certain instances it may be more convenient to mount the unit on the porthand side. The standard unit is sensed to operate on the starboard side of the tiller and where porthand mounting is required a special porthand system must be ordered.

Porthand systems must be fitted with porthand wind vane attachments.

Basic installation method

When the tiller is positioned low in the cockpit and is adjustable in height, the mounting socket can be most conveniently positioned on the starboard cockpit seat. The pushrod is attached to the tiller via the standard ballpin provided which is inserted directly into the top of the tiller. The ballpin is installed by inserting it into a $\frac{1}{4}$ " (6mm) drilled hole and securing with a good quality two pack epoxy adhesive such as Araldite. The shoulder of the ballpin should be positioned $\frac{1}{2}$ " (12.5mm) above the upper surface of the tiller to avoid fouling when the pushrod is fully retracted.

The autopilot mounting socket is installed by inserting it into a 1.2" (12.5mm) drilled hole and permanently bonded with Araldite. It is important to ensure that the mounting socket is securely installed. If the mounting site, for example, consists only of a single glass fibre skin of less thickness than the depth of the socket it will be necessary to provide reinforcement by bonding a plywood strengthening plate to the underside.

The autopilot is capable of generating very high pushrod loads and it must be stressed that in all cases the mounting socket should be very firmly bonded into position.

Extended pushrods

In some cases it may not be possible to provide a convenient site for the mounting socket at the standard mounting distance of 19" (480mm). In such cases the mounting distance can be increased in increments of 1" (25mm) to a maximum of 6" (150mm) with the use of special pushrod extensions. The pushrod is extended by first unscrewing the pushrod end cap and then screwing the pushrod extension into position between the pushrod and the end cap. This attachment is necessary, for example, when the cockpit is unusually wide or when it is convenient to mount the unit on the cockpit coaming.

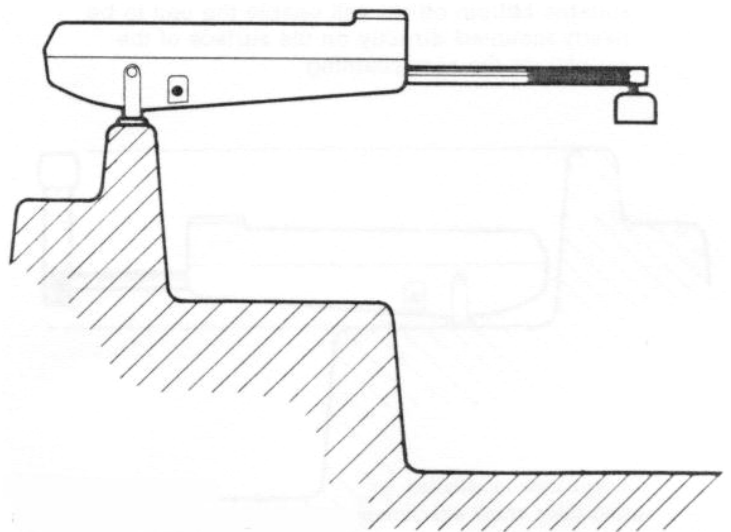

Tiller attachments

When the tiller is not adjustable in height or is positioned appreciably higher than the most convenient site for the mounting socket. It is often convenient to lower the ballpin underneath the tiller. Standard tiller cranks are available in a range of sizes to lower the ballpin centre in increments of 1" (25mm) to a maximum of 5" (125mm) below the underside of the tiller. Since the pushrod centreline is positioned 2" (62mm) above the mounting socket, these attachments can cater for a vertical distance between the mounting socket and the underside of the tiller of up to a maximum of 7" (190mm). This attachment is particularly useful- in the case of transom hung rudder configurations (such as the Folkboat) where the tiller passes over an extended counter. In such cases a tiller crank of suitable ballpin off-set will enable the unit to be neatly mounted directly on the surface of the counter or the rear coaming.

The tiller crank attachments are bolted through the centreline of the tiller, with ¼" (6mm) diameter bolts and since the bolts through the neutral bending axis, the bending strength of the tiller will not be significantly altered. The securing bolts should be locked into the clearance holes through the tiller with epoxy adhesive to ensure that they do not work loose in operation.

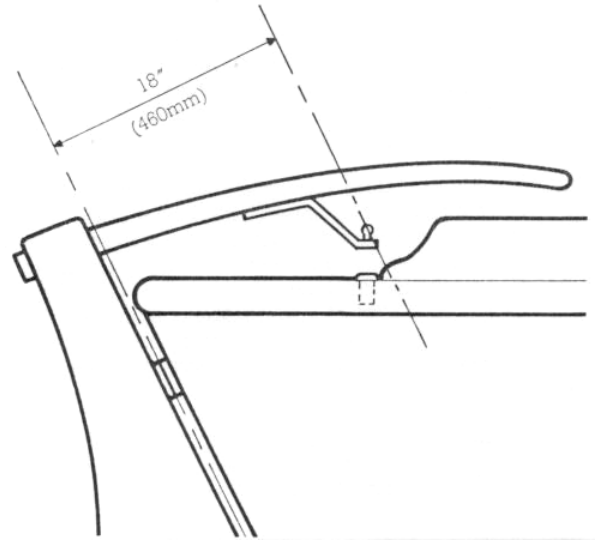
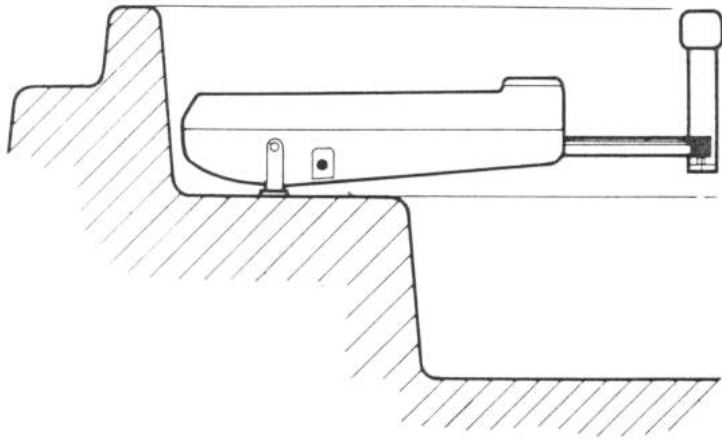

Cantilever mounting

It may sometimes be necessary to attach the autopilot to a vertical face such as the cockpit sidewall. In this case, a special cantilever mounting is available and is particularly convenient when the tiller is positioned substantially higher than the level of the cockpit seat. Full instructions are supplied with each cantilever mounting kit. The standard cantilever mounting kit allows the autopilot mounting socket to be off-set by a maximum of 10" (250mm) from the vertical mounting face. This maximum dimension may be reduced by cutting the cantilever to length during installation. The cantilever screws into a permanently mounted base which is bolted into position by three ¼" (6mm) stainless steel bolts. The cantilever may be unscrewed from its permanent mounting base to allow unobstructed working space when the autopilot is not in use.

Pedestal mounting

In certain cases it may be convenient to raise the height of the autopilot mounting socket above the cockpit seat or counter for example. Standard pedestal assemblies are available to raise the mounting height from 1½" to 3½" above the mounting surface in ½" (12.5mm) increments. The pedestal base is bolted into position by three ¼" (6mm) stainless steel bolts. When the autopilot is not in use the pedestal may be unscrewed from its base to allow clear working space when necessary.

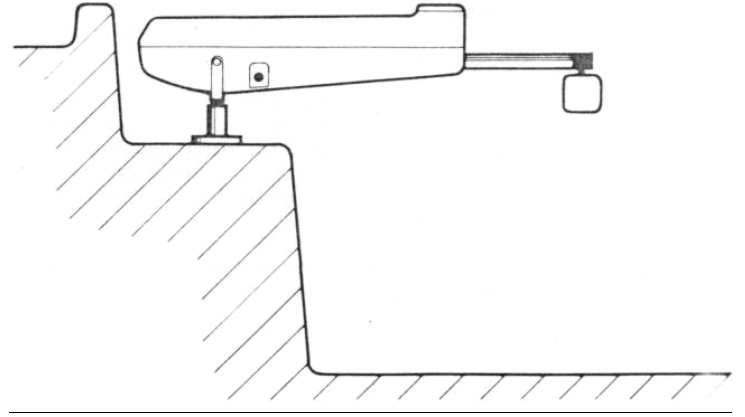
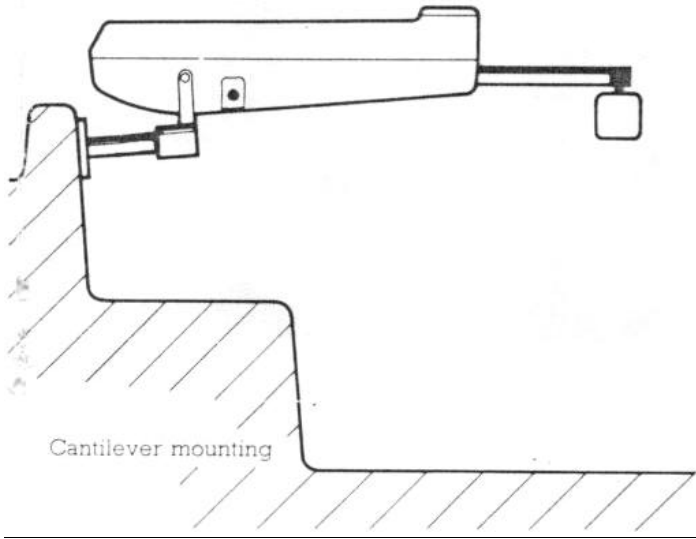

Use of attachments

In very many cases the autopilot can be installed without the need for special attachments. Where this is not easily possible the above standard attachments will normally provide a neat solution and avoid the need for structural alterations. In very rare cases where the standard range of attachments do not provide a convenient mounting arrangement it may be necessary to consider the use of purpose made attachments. In the event of difficulties occurring, our Technical Sales Department will be pleased to advise.

Battery connection

For trial purposes the actuator power lead may be connected directly to the vessel's 12 volt battery. The **brown** lead should be connected to the **positive** terminal and the **blue** lead to the **negative** terminal. If the power connections are accidentally reversed the autopilot will not function but no damage will result.

It is recommended that a waterproof plug and socket is situated adjacent to the unit and the power lead shortened. A standard 5 amp fuse should be provided in the power supply circuit to protect the internal supply cable between the battery and the waterproof outlet socket.

NB The equipment must not be connected to a battery charger for testing.

Wind vane attachment

The wind vane attachment consists of two basic modules - the mounting mast which elevates the wind vane into clear wind and the wind vane transducer head which attaches to the clevis at the head of the mast by means of the cranked key provided. The wind vane transducer is electrically connected to the main autopilot unit by means of the waterproof jack plug on the end of the interconnecting cable. When the wind vane is not in use and the waterproof plug is disconnected special care must be taken to ensure that the rubber blanking plug attached to the socket on the main autopilot unit is firmly pushed into position. If this is not done water could enter the jack socket and temporarily disable the autopilot until the water is dried out.

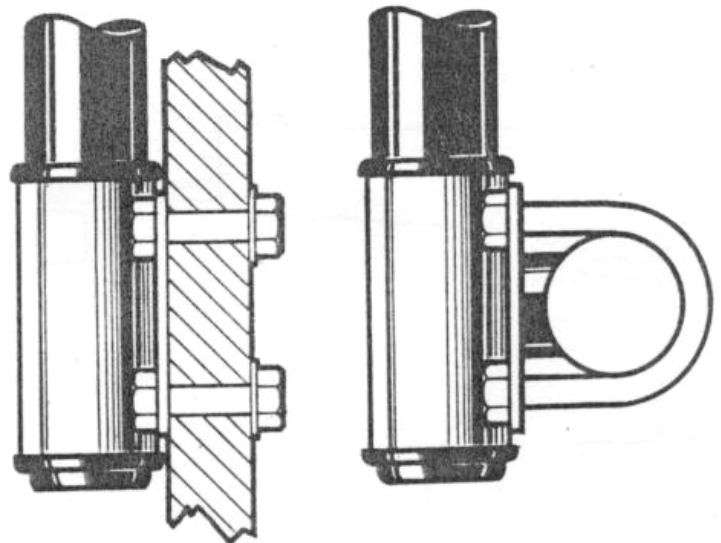

Similarly when the jack plug is inserted in wet cockpit conditions, extreme care should be taken to ensure that the plug is kept dry. Occasional lubrication of the jack plug with Vaseline will help to minimise problems of water intrusion. Once the jack plug has been inserted, the connection is absolutely watertight.

The wind vane transducer mounting mast is normally clamped centrally to either a vertical or horizontal rail of the after pulpit using the 'U' clamps provided. In the event of an after pulpit not being fitted the mounting flange may be bolted directly to a suitable vertical face. Care must be taken to ensure that the wind vane transducer is in clear wind on both tacks and not too close to the deflected air stream from the mainsail. This is normally ensured by situating the mounting mast centrally behind the backstay and by elevating the wind vane at least 2ft (60cm) above the highest deck obstruction.

Feedback linkage

The autopilot operates on the principle of mechanical feedback between the sensors and the rudder to correlate corrective rudder action with off course error.

To complete installation of the wind vane attachment, the feedback drive cord emerging from the base of the mounting mast must be connected to the pushrod. You will see that when the feedback cord is pulled out of the mounting mast against spring tension, backlash free rotational movement of the wind vane transducer results.

Two small blocks are provided for leading the feedback cord to the tiller. Normally only one block is necessary to obtain a clear run out but occasionally two blocks may be necessary to avoid obstructions such as the mainsheet. The final fairlead should be positioned aft of the actuator unit as shown so that the final run of the feedback cord is orientated nearly at right angles to the tiller. It is important that the final fairlead is positioned below the centreline of the pushrod so that the spring tension on the cord has a tendency to pull the pushrod down onto the tiller pin.

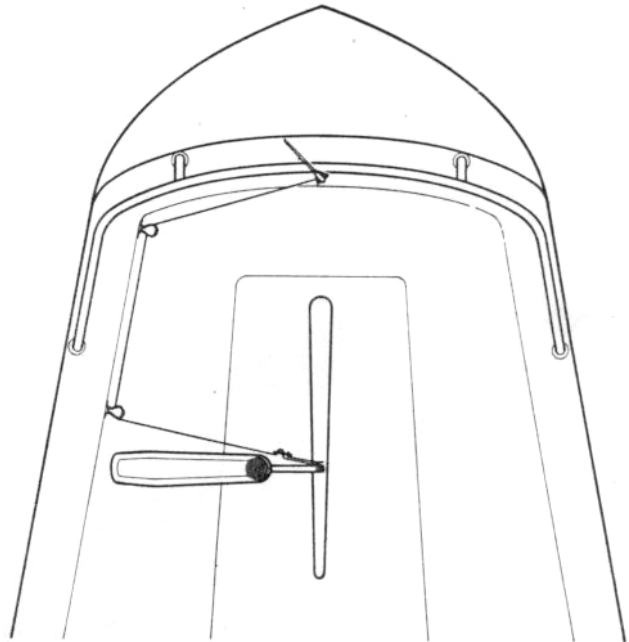

Feedback Linkage

Finally, a loop is formed on the end of the feedback cord after cutting to length and made fast by means of the plastic adjustor slide provided. The end of the loop is positioned so that the feedback cord is just under tension when attached to the hook on the end of the pushrod in the fully retracted position. This ensures that the feedback cord is under tension over the full stroke of the pushrod. If the feedback cord is over tensioned, the remaining free scope of movement may not be sufficient to accommodate the full stroke of the pushrod and may cause damage to the feedback mechanism at the full extremity of pushrod travel. After adjusting the cord tension as described above, carefully check that the remaining scope of feedback cord movement is sufficient to accommodate the full stroke of the pushrod.

After rigging the feedback cord, check that the wind vane transducer head rotates smoothly over the full stroke of pushrod movement. Backlash free vane head movement is essential to ensure accurate steering performance.

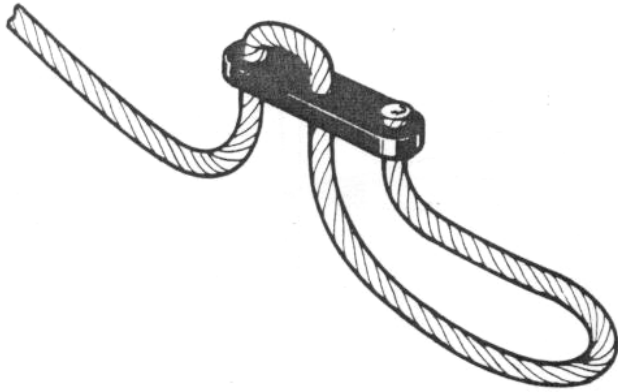

Operation

Functional test procedure

After completing the installation you should carry out the following functional test to familiarise yourself with the system before attempting sea trials.

The autopilot is fitted with a 4 position thumb operated rotary switch located on the upper case. The autopilot is switched **off** when the thumb control wheel is in the fully anti-clockwise position. The remaining 3 positions of the control switch provide the following functions.

Calm
selects compass operation for 'calm' weather conditions.

Rough
selects compass operation for 'rough' sea conditions.

In this position minor yawing motions caused by wave action are neglected. The autopilot will respond only to changes in mean course, and thus the duty cycle and power consumption will be substantially reduced.

Vane
selects wind vane control and enables convenient transfer of control mode when the wind vane attachment is fitted.

Operation under compass control

- Hold the unit towards the tiller and rotate the compass dial until the cardinal point graduations are approximately aligned with your main steering compass.
- Switch to **calm** and note that the north graduation on the compass dial then automatically homes to magnetic north.

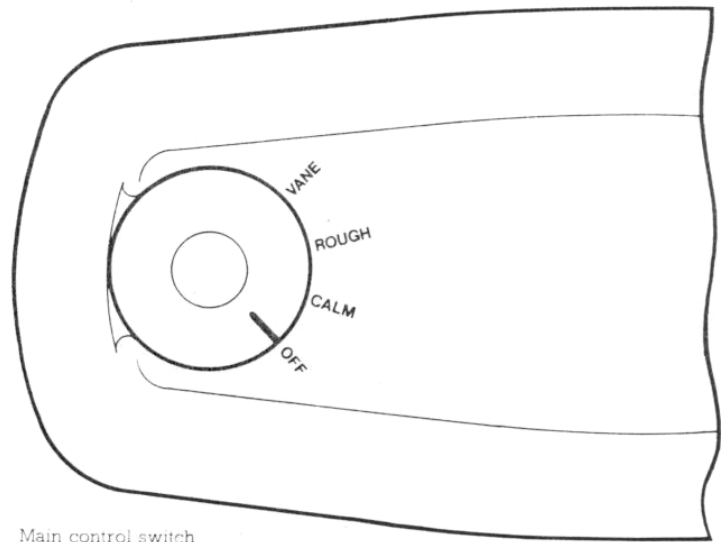

Main control switch
Main Control Switch

Rotate the compass dial in small increments until the end of the pushrod remains settled over the tiller pin and clutch onto the tiller. Rotate the compass dial clockwise to retract the pushrod and anti-clockwise to extend it. Note that after making adjustments, it is necessary to release the compass dial to allow the compass to realign with the earth's magnetic field.

If the yacht is swinging about its mooring, you will see that small variations in heading cause the unit to apply corrective action to the rudder. Now switch to **rough** and note that the frequency of corrective action is reduced.

Operation under wind vane control

If the system is fitted with a wind vane attachment the following familiarisation test may be carried out.

- Connect the wind vane jack plug to the main actuator and attach the feedback cord to the end of the pushrod.
- Set the wind vane head into its most sensitive position by tilting the head forward until the vane is almost vertical. Then grip the mounting mast just above its base and slowly rotate until the vane feathers into wind. In this position the vane will flutter evenly between the buffers.
- Switch over to **vane** to transfer the sensing mode to wind vane control.

Note that small variations in wind direction will now cause the actuator unit to apply corrective action to the rudder. This is how the Autohelm 1000 functions when under sail.

Rotate the mounting mast a little further and note how the tiller takes up a new position to one side. This is how trim corrections are made for weather or lee helm when under sail.

Finally, tilt the vane head back until the vane is nearly horizontal. This de-sensitises the wind vane, and you will note that the frequency of corrective rudder action is noticeably reduced.

Operation under sail

Preferably, initial trials should be carried out in reasonably calm conditions and with plenty of sea room.

The following familiarisation procedure is recommended.

Compass control

- Steer onto a fixed heading under engine or sail and hold the course steady.
- Holding the pushrod towards the tiller, rotate the compass dial until it is approximately aligned with the yacht's main steering compass and switch to calm.
- Allow the compass to automatically align with the earth's magnetic field and then adjust the compass dial further until the end of the pushrod is approximately positioned over the tiller pin.
- Clip the pushrod onto the tiller and allow the autopilot to take over.

- After allowing the boat to steady onto an automatically controlled heading, carry out small incremental adjustments to the compass dial until the vessel steadies on to the desired heading. Note that clockwise adjustment of the compass dial will alter course to port.
- The vessel may now be steered onto any other heading by adjusting the compass dial. If the autopilot appears to be working continuously due to sea conditions, switch over to rough. The rate of working will then reduce substantially.

Wind vane control

When the system is fitted with a wind vane attachment it will in general be easier to set up under compass control first as described above, and then to switch over to wind vane control.

First trials under wind vane control are best carried out when sailing to windward slightly off the wind

- When the vessel is sailing steadily under a magnetically controlled heading, the wind vane mast should be rotated to feather the vane to wind.
- Switch over to vane and the actuator will then respond to variations in wind direction.
- When the vessel has steadied onto a wind-controlled heading, carry out small rotational adjustments to the vane mounting mast until you are satisfied that you are sailing on an optimum course to windward.

Note that to adjust the yacht's heading you rotate, the vane stanchion in the same direction as you would the tiller. You will find also that to trim your course only very small movements should be applied to the vane stanchion.

- Repeat the above procedure broad reaching and finally running down wind by progressively slackening the sheets and slowly rotating the vane to bring the vessel onto the new headings.

Disengagement

The pushrod is held into engagement with the tiller pin merely by the weight of the actuator unit. This method of engagement is secure and has been adopted for safety reasons to allow the pushrod to be easily disengaged when manual override becomes necessary.

Operating hints

Sail balance

It is always advisable when sailing under automatic pilot control to pay strict attention to sail balance. Good sail balance is particularly essential in gusty conditions and strong winds.

When a yacht is sailing badly out of balance, sudden gusts will generally cause it to luff violently to windward. When hand steering, this tendency is corrected by applying sufficient weather helm to hold the original course until the gust subsides. A simple autopilot, however, does not understand the need for weather helm and will, therefore, allow the yacht to luff to windward until sufficient helm is applied to achieve a new state of balance.

Furthermore, it will maintain the luffed heading for as long as the need for increased weather helm 'persists. Contrary to popular opinion a proportional steering autopilot will not maintain a constant heading when the yacht's balance changes. Thus sailing badly out of balance in varying wind strengths will always give rise to excessive course wander. This tendency is best overcome by reefing the mainsail slightly more than you would when hand steering.

On longer passages when a constant compass course may be steered for hours on end, variations in wind strength and direction will almost certainly cause changes in helm balance. For the same reasons given above, variations in standing helm will cause the autopilot to steer slightly away from the set course. In the case of the Autohelm 1000, if 5 degrees of additional weather helm is required as a result of rising wind strength, for example, the course steered by the autopilot will correspondingly change by approximately 20 degrees. Thus when passage making, if a change in compass heading is observed, the original course should ideally be restored by re-trimming sails to obtain the original state of balance. Alternatively, providing weather helm has not become excessive, the yacht may be trimmed back on to the original heading by re-adjusting the autopilot's compass setting.

Vane sensitivity adjustment

Normally the wind vane is set almost vertically to operate at near maximum sensitivity. High vane sensitivity is essential to ensure optimum penetration to windward when sailing close-hauled and usually does not result in excessive actuator activity. The sensitivity of the vane may be reduced by tilting the entire unit backwards on its clevis mounting. This has the effect of increasing the 'dead band' of the vane sensor by allowing up to a maximum of 15 degrees course variation to occur before automatic correction is applied. When it is not necessary to sail a very accurate course, lowering the sensitivity of the vane in this manner will reduce the number of corrections made and hence reduce power consumption. In heavy weather or turbulent wind conditions, the duty cycle of the autopilot can usually be lowered by de-sensitising the wind vane. De-sensitising the wind vane under these conditions will not affect the accuracy of the mean course steered.

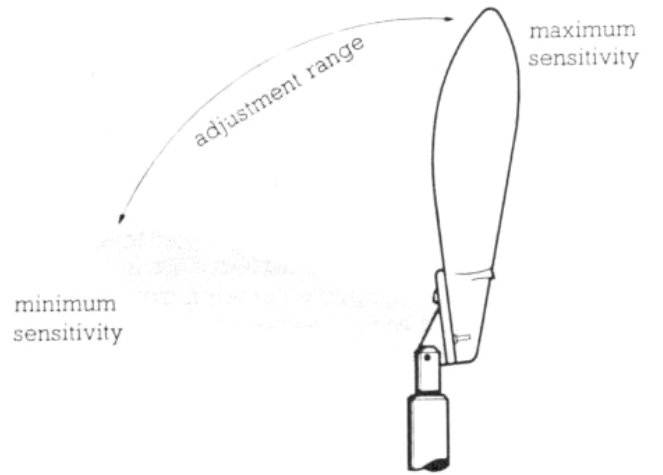

Selection of transducer

When the wind vane attachment is not fitted it is possible to use the basic magnetic sensing unit under both engine and sail. It should be borne in mind, however, that the compass sensor is internally gimballed to cope with a maximum angle of heel of 30 degrees, and will not operate beyond this heel angle. It will also be necessary to lay slightly off the wind when sailing long passages close-hauled to prevent becoming backed by gradual shifts in wind direction.

Wind vane control is always more efficient when sailing close-hauled when it will ensure that immediate advantage is taken of changing wind direction to ensure optimum penetration to windward. In steady wind conditions, wind vane control will. Usually give best results on all other points of sailing.

When the wind is abaft the beam and unsteady in strength and direction surprisingly large variations in apparent wind direction can occur. Under these conditions compass control generally improves course keeping accuracy.

Tacking in enclosed waters

When the wind vane attachment is fitted the system can be set up to automatically tack the vessel by alternately switching over from compass to wind vane. This is done by setting the vane to control on the longest tack and the compass sensor on the other. Tacking is then simply achieved by switching over from one mode to the other leaving you free to handle the sheets.

Watch-keeping

As a final caution. it is very easy to relax permanent watch-keeping, and this temptation must be avoided however clear the sea ahead may appear to be. Remember that a large ship can cover two miles in five minutes -just the time it takes to brew a cup of coffee!

Stowage

After use, the Autohelm 1000 system is easily stowed by unclipping the actuator unit from its mounting, and removing the vane transducer from its mounting mast. The entire system can then be stowed easily in a small locker.

Maintenance

All moving parts of the system have been lubricated for life at the factory. Therefore no maintenance whatsoever will be required. Should a fault develop, the entire unit should be returned in the original packing case for repair and servicing, which will be carried out speedily and at a moderate cost.



Raymarine Ltd.
Anchorage Park
Portsmouth
Hampshire
PO3 5TD
Tel 023 9269 3611

Fax 023 9269 4642

www.raymarine.com